

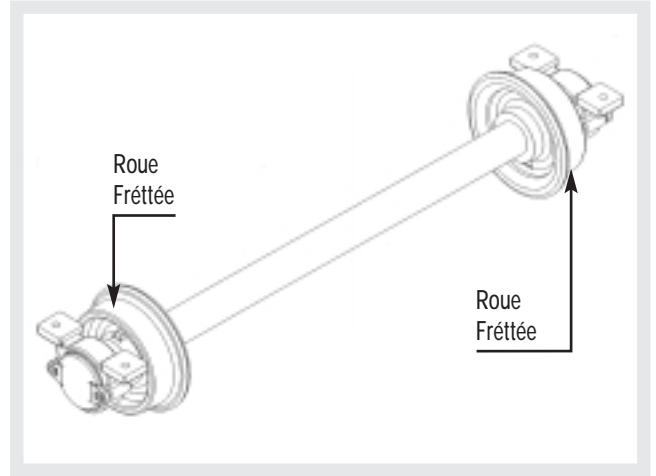

ESSIEUX TYPE 81 : montage 813 motorisable

AXLES TYPE 81: mounting 813 can be motor driven

ESSIEU MENÉ : ROUE NON DÉMONTABLE - DRIVEN AXLE: NO REMOVABLE WHEEL

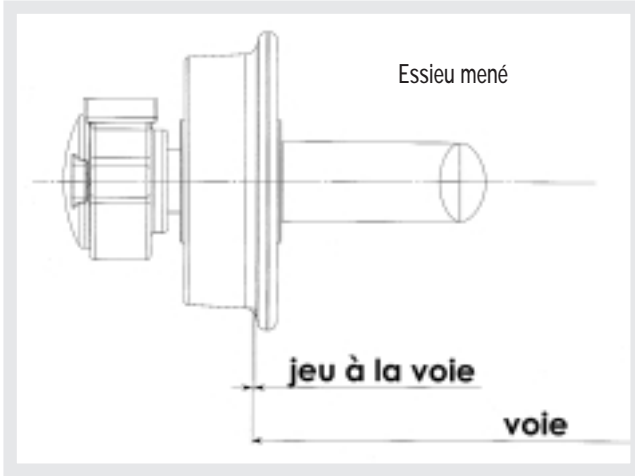

ESSIEU MOTORISABLE : UNE ROUE DÉMONTABLE- MOTOR DRIVEN AXLE: REMOVABLE WHEEL

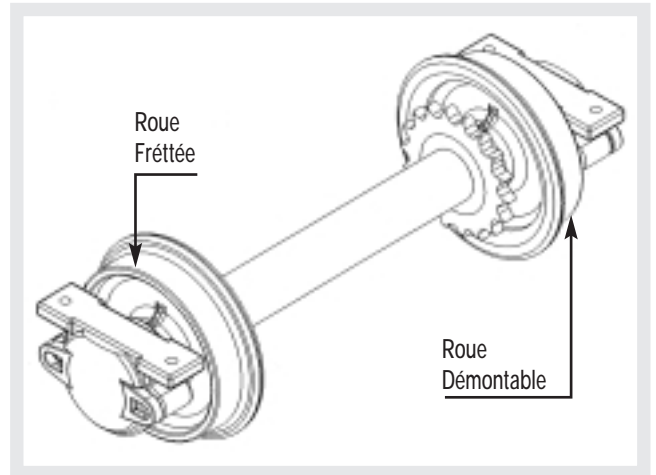
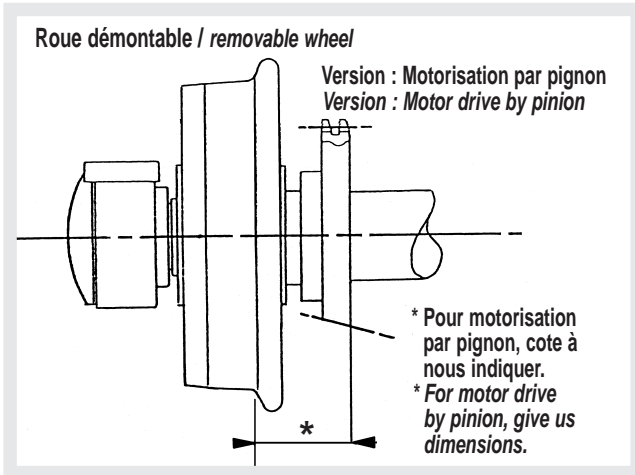

ESSIEU MOTORISABLE : ROUE NON DÉMONTABLE - DRIVEN AXLE: NO REMOVABLE WHEEL

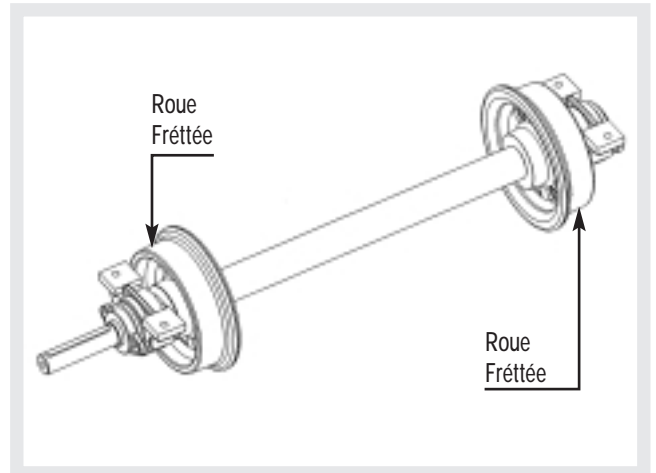
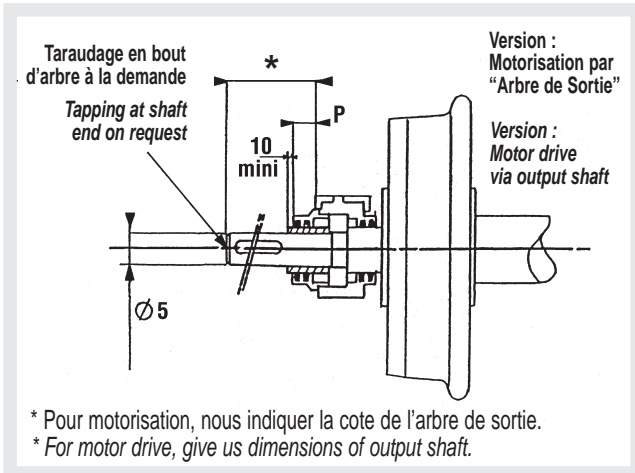

Roue non démontable / Unremovable wheel

| Roues Wheels | Charge en t Load/t | Paliers Bearers | Roulements Bearings | Voie Gauge | Ø1 | Ø2 | Ø3 | Ø4 | Ø5 | A | B | C | F | G | H | I | J | K | L | P | Q |
|-----------------|-----------------------|---------------------------|------------------------|---------------|-----|-----|-----|-----|----|------|-------|------|------|------|-----|-----|-----|-----|----|----|----|
| 150 FM | 2 | TVN 308 | 21308 | 1000 | 150 | 182 | 60 | M12 | 40 | 85 | 65 | 946 | 1168 | 1332 | 60 | 210 | 60 | 170 | 20 | 26 | 35 |
| 200 P | 1,5 | TVN 307 | 21307 | 1000 | 200 | 240 | 50 | M12 | 35 | 61 | 49 | 962 | 1132 | 1288 | 60 | 210 | 60 | 170 | 18 | 24 | 35 |
| 250 M | 4 | TVN 308 | 21308 | 1000 | 255 | 290 | 65 | M12 | 40 | 80 | 58 | 930 | 1150 | 1314 | 60 | 210 | 60 | 170 | 20 | 26 | 35 |
| 250 DM UIC | 5 | TVN 309 | 21309 | 1000 | 250 | 314 | 90 | M16 | 45 | 135 | 102,5 | 911 | 1232 | 1406 | 70 | 270 | 70 | 210 | 23 | 22 | 40 |
| 300 M | 6 | TVN 311 | 21311 | 1000 | 305 | 350 | 80 | M16 | 45 | 81,5 | 60,5 | 946 | 1156 | 1356 | 80 | 290 | 80 | 230 | 25 | 25 | 45 |
| 300 L | 10 | TVN 313 | 21313 | 1000 | 308 | 360 | 110 | M20 | 55 | 95 | 84 | 932 | 1208 | 1428 | 90 | 330 | 95 | 260 | 28 | 25 | 50 |
| 320 D UIC | 10 | TVN 314 | 21314 | 1000 | 325 | 389 | 100 | M20 | 60 | 135 | 102,5 | 895 | 1243 | 1471 | 90 | 330 | 95 | 260 | 28 | 27 | 50 |
| 400 MT | 15 | TVN 315 | 21315 | 1440 | 400 | 464 | 100 | M20 | 65 | 135 | 102,5 | 1349 | 1691 | 1937 | 100 | 360 | 100 | 290 | 30 | 26 | 55 |
| 450 R | 15 | TVN 315 | 21315 | 1440 | 450 | 510 | 100 | M20 | 65 | 135 | 100 | 1334 | 1703 | 1949 | 100 | 360 | 100 | 290 | 30 | 26 | 55 |
| 450 R | 20 | Sur étude / To be studied | | | | | | | | | | | | | | | | | | | |
| 450 RT | 25 | " " | | | | | | | | | | | | | | | | | | | |
| 600 UIC | 25 | " " | | | | | | | | | | | | | | | | | | | |

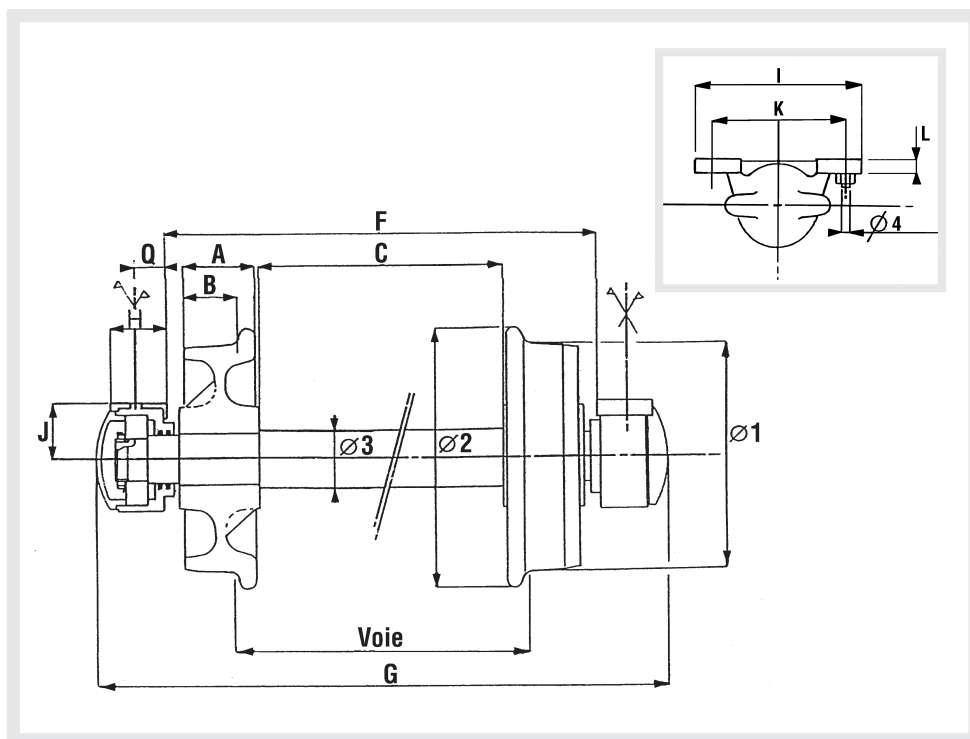

Fixation du châssis
sur paliers extérieurs.

Fixing of chassis
on external bearers.

Nota : Essieu équipé de roues diamètre minimum 150 mm.
Tous les essieux 81 peuvent être exécutés en montage 813 (motorisable). Nous consulter pour étude et mode de motorisation.
Les cotes des essieux ci-dessous sont données à titre indicatif.

Note : Axle equipped with wheels minimum diameter 150 mm.
All the axles can be constructed according to the 813 mounting (motor driven). Contact us for survey and motor drive type.
The hereafter axle dimensions are given for information.

Pignon non prévu dans fourniture / Gear RIM is not supply

Les charges doivent être uniformément réparties / Loads should be uniformly distributed among wheels.

Les tonnages supérieurs sont à considérer sur étude selon rail et usage hors embranchement particulier (ITE Installation Terminale Embranchée). Les cotes et la force sont données pour la voie de référence. Ces essieux sont réalisables pour un autre écartement sur demande.

Greater tonnages will be considered after study according to rails and use outside specific branch line (ITE = Terminal Branch line Installation). Measurements and ratings are given for the reference track. These axles can be made for other gauges on request.



LE SPÉCIALISTE DU RAIL ET MANUTENTION SUR RAIL
RAIL AND ON-RAIL HANDLING SPECIALIST

SIEGE SOCIAL - REGISTERED OFFICE

23, rue de la Boétie - 75008 PARIS - FRANCE

S.A. au capital de 400.000 € - Limited Company with a capital of 400.000 €

SIREN 702 033 077 - NAF 352Z

SERVICES COMMERCIAUX - COMMERCIAL SERVICES

24, rue du 8 Mai 1945 - 95340 PERSAN - FRANCE

Tél. : 01 39 37 45 45 - Fax : 01 39 37 45 44

www.patry.fr - e-mail : info@patry.fr